



# **Guide to Fire Protection in Houses in Multiple Occupation**

---



---

**This guide outlines the fire safety standards recommended in HMOs in Hertfordshire.**

## **Guide For Owners, Agents and Managers of HMOs**

---



## **Foreword**

Local Authorities of Hertfordshire with Hertfordshire Fire and Rescue Service have produced this document to provide owners, managers, letting agents, and contractors with the necessary information to help them provide their tenants with safe and high quality accommodation and reduce the need for intervention from the Local Authority. This is however guidance and the requirements in individual properties may vary dependent on the risks presented, if you have any questions or believe your property does not fit those detailed in this document you should contact your Local Authority.

The Government believes that safe and properly managed Houses in Multiple Occupation (HMOs) fulfil an important function in the private rented housing market. HMOs have a particular role in providing affordable accommodation in areas of high housing demand where other rents may be high.

We aim to encourage the supply of good quality private rented homes, and provide, and facilitate, information and training for landlords.

We would like to acknowledge the assistance of “Homestamp”, a partnership consortium in the West Midlands in the preparation of this document. Their contact email address is:

[www.homestamp.com](http://www.homestamp.com)

***For further information or assistance on HMOs please contact your local Environmental Health department.***



## Contents

---

Purpose of this guide and how to use it	Page 6
<b>Part 1</b>	
What is an HMO	Page 7
Why is fire safety important?	Page 7
<b>Part 2</b>	
Fire prevention	Page 8
<b>Part 3</b>	
General principles for fire precautions	Page 10
<b>Part 4 - Example Layouts and general specifications</b>	
Key to plans	Page 11
Plan 1, two storey with shared cooking facilities	Page 12
Plan 2, two storey with individual cooking facilities	Page 14
Plan 3, three storey with individual cooking facilities	Page 16
Plan 4, three storey with shared cooking facilities	Page 18
Plan 5, two storey with basement	Page 20
Plan 6, three storey above commercial premises	Page 22
<b>Part 5</b>	
Maintenance of fire precautions	Page 24
<b>Part 6 – Technical Specifications</b>	
Fire detection and alarm systems	Page 26
Model certificate for alarm systems	Page 29
Emergency lighting	Page 30
Signs and notices	Page 30
Fire resistance of walls and partitions	Page 30
Upgrading of floors and ceilings	Page 34
Fire resisting glazing	Page 36
Safety glazing	Page 37
Additional escape route separation	Page 37
Fire doors	Page 38
Escape windows	Page 39
<b>Part 7</b>	
Example maintenance record	Page 41
<b>Part 8</b>	
Sprinkler systems	Page 43

## **Purpose of this Guide**

This guide outlines the standards of fire precautions normally necessary in a variety of layouts of HMO properties that are commonly encountered in Hertfordshire. It does not however represent legal requirements; these would be determined through a risk assessment upon inspection of each individual property. The purpose of this guide is to aid landlords in meeting these standards, by independently and pro-actively upgrading their properties, without the need for intervention by the Local Authority.

**The Housing Act 2004 takes the view that someone with overall control of the house, (i.e. the owner, landlord or manager) must take steps to protect everyone living in it.**

In standard layout properties it is likely that completion of the works in this document will suffice. However, it may be necessary for additional or different works to be undertaken in particular circumstances. If you have any questions, and in particular if the layout of your property is not shown in this document you should contact your local Environmental Health department for advice prior to undertaking any works.

**Alternatives to these standards will be considered if they provide a sufficient level of protection to residents. It may be necessary to undertake a fire risk assessment to demonstrate this. The Council and the Fire Service must agree to any alternative solutions. An example of alternative fire safety precautions is installation of a sprinkler system – an example specification of this is included at the back of this document.**

There are further requirements under housing legislation, for example, space and amenity standards which may also need to be met. In particular, three storey HMOs with five or more residents will need to be licensed by your Local Authority. For certain conversion, alteration or improvement works you may require planning permission or approval from Building Control, you should always seek advice from the Council prior to converting or renovating a property.

Licensed HMOs are also required to produce a Fire Safety Risk Assessment. This is good practice for all HMOs and further guidance and examples can be sought from your Local Authority or Hertfordshire Fire and Rescue Service.

## **What is in this Guide?**

**Part 1 outlines what an HMO is for Housing legislation purposes and explains why fire safety is important.**

**Part 2 details the fire prevention measures you should take even before you complete any upgrading works. It is recommended that you implement these measures in single family dwellings as well as HMOs.**

**Part 3 outlines the general principles of fire precautions in HMOs.**

**Part 4 gives examples of standard layouts of properties and outline specifications of what fire precaution works are required.**

**Part 5 details the maintenance required once upgrading is completed.**

**Part 6 gives the technical specification for the different requirements of upgrading – this is lengthy and you do not need to read all of this until you begin your upgrading.**

***Part 4 and part 6 can be copied and given to your contractors to aid in specifying the requirements of the works.***

**Part 7 has some example forms that you can use to record your maintenance and routine checks of fire precautions. Should a fire occur these records will demonstrate your ongoing management of the property and will be taken into consideration by the Local Authority and Hertfordshire Fire and Rescue Service should it be necessary to consider formal action.**

## **Part 1 What is an HMO and why is fire safety important?**

### **Houses in Multiple Occupation (HMOs)**

Definition of an HMO:

A House in Multiple Occupation is a building or part of a building that is:

- a) occupied by more than one household who share an amenity such as a bathroom, toilet or cooking facilities; or
- b) converted self contained flats that do not meet the 1991 Building Regulations, where at least one third of the flats are occupied under short tenancies.

The term *occupied* means that it is the occupants only or main residence, but it does also include properties where students live in term time only.

People are classed as separate households if they are not family members or co-habiting couples.

There are exemptions to these rules and further information can be obtained from your Environmental Health department.

**This document does not detail fire precaution recommendations for self contained flats that are HMOs. You should contact your Local Authority for advice in relation to these properties.**

### **Why is fire safety important?**

HMO accommodation has often been created by sub division of larger properties into smaller units and this often increases the risks that a fire will occur. In addition, the means of escape may have been compromised in the process of redevelopment making it less likely that occupants will get out of the building safely should a fire occur. Deaths and injuries from fires in HMOs are more likely than in single family homes.

**The main reasons for insisting on fire precautions in Houses in Multiple Occupation (HMOs) are to provide early warning, and to stop the smoke and fire spreading to parts of the property before other residents have the chance to escape.**

## **Part 2 - Fire Prevention**

The most important action you can take as a property manager is to try and prevent fires. Whilst the advice given in this booklet has mainly been concerned with methods of warning residents of a fire and preventing the spread of the fire to enable them to escape; fire precaution measures can never guarantee absolute safety for residents, or prevent extensive property damage.

The most important steps that you, as an owner or manager can take to minimise the risk of a fire are:

<b>Electrics</b>	<p><b>Make sure that the electrical circuits, fittings and equipment throughout the house are in good condition. Have the electrical installation checked regularly by a competent electrician (NICEIC or ECA approved) and act quickly on any recommendations that are made.</b></p> <p>The electrician's report will tell you the date on which the installation should be checked again. Install circuit breakers and prevent overloading of sockets by ensuring the adaptors are not needed.</p> <p>If you buy new electrical equipment, make sure that it bears the CE mark, either on the equipment itself, or on the box, to show that it complies with legal standards. The purchase of second hand electrical goods is not recommended.</p>
<b>Gas</b>	<p><b>Have the gas installation (i.e. the gas pipework, meters, gas fires, cookers, boilers, water heaters and flues) checked, and serviced at least once a year by a CORGI registered gas fitter. This is a legal requirement under the Gas Safety (Installation and Use) Regulations. You must give a copy of the safety certificate to each resident within 28 days, and give a copy to new residents before they move in.</b></p>
<b>Location</b>	<p>Make sure that heaters and cookers are fixed in a position where they will not set fire to curtains, bedding or furnishings.</p>
<b>Furniture</b>	<p><b>Make sure that all upholstered furniture that you, as the landlord, provide (such as settees, armchairs, bed bases and mattresses) has sewn-in labels showing that it has fire-resistant filling and covers. This is a legal requirement under the Furniture and Furnishings (Fire) (Safety) Regulations 1988 and the Furniture and Furnishings (Fire) (Safety) (Amendment) Regulations 1993.</b></p>
<b>Flammable materials</b>	<p>Discourage the use of portable gas or paraffin heaters in the house. Do not store highly flammable materials in the house (such as paint, thinners, LPG cylinders, paraffin or petrol).</p>
<b>Combustible items</b>	<p><b>Do not store large quantities of combustible materials such as cardboard boxes or newspapers, in understairs cupboards, cellars, or in the loft.</b></p>

**Inform your residents of the following information and make sure they understand the importance of:**

The dangers of:

- smoking in bed or when drowsy
- careless use of candles or joss sticks
- overloading electrical sockets
- having trailing cables
- leaving a chip pan or frying pan unattended, or over-full of oil or fat
- placing clothes to dry over or near heaters

and the importance of a bedtime fire safety routine:

- turning off the cooker
- unplugging electrical appliances (except those designed to remain on)
- making sure that no cigarettes or candles are left burning
- closing all doors

You should advise residents that in the event of a fire:-

- Do not attempt to fight fires that have already taken hold – evacuate yourself from the house. If you share the house with other people sound the alarm as you make your escape.
- Do not try to rescue belongings or pets. Your life and the lives of other residents are too precious to risk.
- Telephone the Fire Brigade on 999 immediately from a place of safety. Speak slowly and try to be calm answering the questions you are asked. If you think there may be someone left in the building inform the 999 operator.

**A template leaflet/poster may be available from your Local Authority.**

### **Part 3 - General Principles for Fire Precaution Standards**













The HMO's design, construction and condition must limit the spread of fire and smoke and provide a safe and ready means of escape. There must be adequate fire protection to the means of escape and between each unit of accommodation, with appropriate detection and alarm systems provided. Emergency lighting and fire blankets shall be provided where necessary.

1. Every risk room (bedroom, living room, kitchen) needs a mains wired detector/alarm. These will detect fires at the earliest opportunity and ensure that warning is sounded.
2. The detectors normally need to be linked so that everyone in the house is alerted when the alarm sounds.
3. Emergency lighting illuminates the escape route to show persons the way out if the electricity supply is interrupted.
4. The stairwell, landing, and hall are kept clear of obstruction so that people can get out without tripping or bumping etc.
5. All risk rooms (bedroom, living room, kitchen) need 30 minute fire resisting doors with smoke and heat seals and self-closing devices. The fire door slows down the spread of smoke and fire so people can move past it to exit the house. Fire doors are provided to protect the route of escape and should never be wedged open.
6. The methods of locking or fastening risk rooms and escape room doors should not prevent them from being opened internally without the use of a key.
7. Fire blankets and fire extinguishers can be useful in tackling small fires, and preventing their uncontrolled spread, but on balance it is best to encourage people to get out of the house quickly and call the Fire Service. There are injuries every year as a result of ineffective or inappropriate use of equipment. Where equipment is provided, all residents must receive proper instruction in the use of it. Therefore, whilst fire blankets should be provided to all cooking facilities normally there will be no requirement for fire extinguishers.
8. Where a basement or commercial premises are present, these shall be separated from the residential area by structure including doors providing 60 minutes fire protection. See plan 5 and 6 of Part 4.

## **Part 4 - Detailed Fire Precautions Required**

The following pages include some typical examples of house layouts and recommended works. Remember that these are suggested ways of complying with the basic principles. There may be other options and you should discuss these with your Local Authority.

### **Key to plans**

	30 minute fire resistance (wall/door/ partition etc..)
	1 hour fire resistance (wall/door/ partition etc..)
	Smoke Detector - interlinked, mains wired
	Heat Detector - interlinked mains wired with battery back up
	Smoke Detector - independent mains wired. (recommended hush facility.)
	Fire Blanket
	Emergency Light
	Control Panel - for fire detection system
	Break Glass Point
	Emergency Escape Window
	Loft hatch – 30 minute fire resistance
	Electric meter to be boxed in to 30 minute fire resistance
	Gas meter to be boxed in to 30 minute fire resistance

Plan 1, House Type: Typical two storey house with Shared Cooking Facilities.

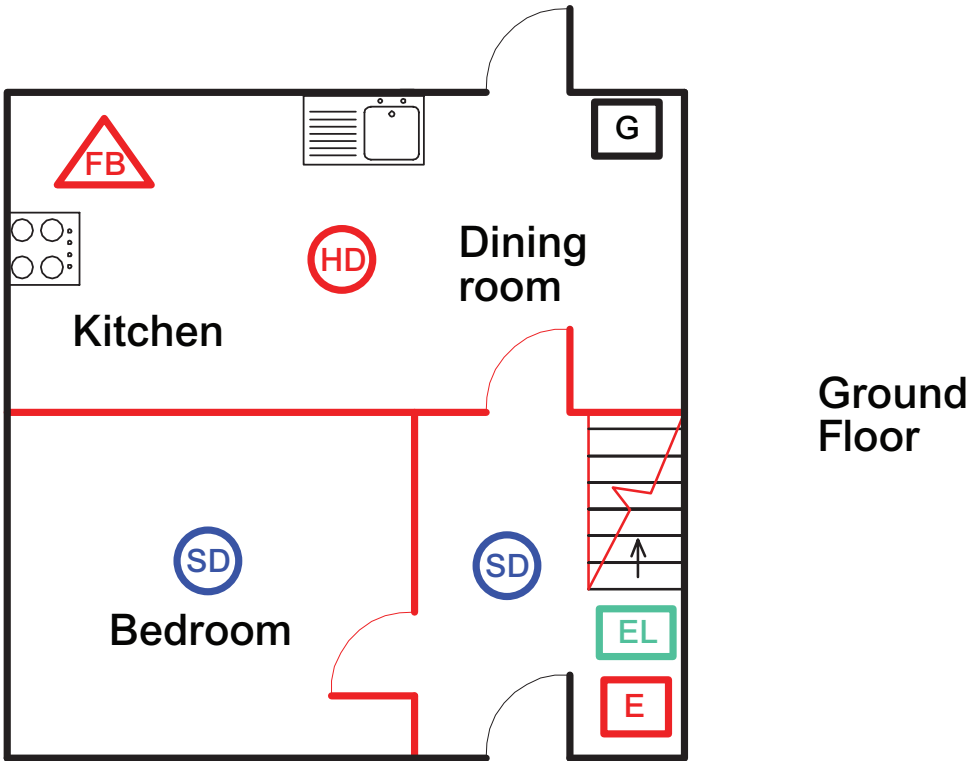

Ground Floor

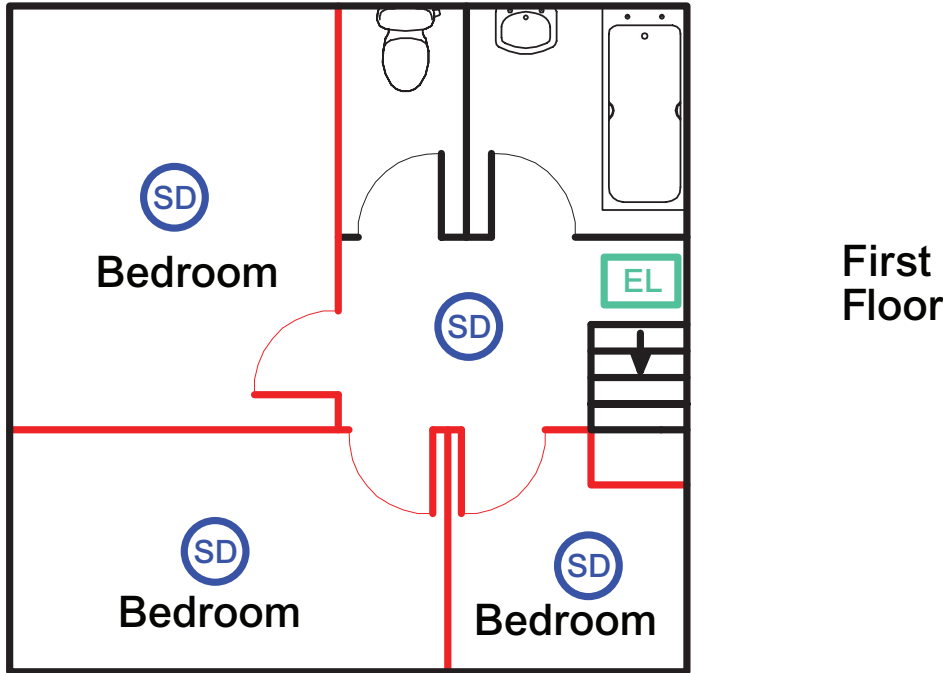

First Floor

## **Outline requirements for example property - Plan 1**

<p><b>Detection/ Warning</b></p>	<p>A system of mains powered automatic smoke detectors and heat detectors with battery back up and built in alarm to achieve BS 5839 Part 6: Grade D (or equivalent). Detectors must be sited in all areas containing a fire risk. In kitchens a heat detector rather than a smoke detector must be installed. All detectors must be interlinked so that if one detector is triggered, the alarm sounds in each and every alarm location. See page 26 for specification.</p>
<p><b>Call Points</b></p>	<p>Not required.</p>
<p><b>Control Panel</b></p>	<p>Not required.</p>
<p><b>Emergency Lighting</b></p>	<p>The equipment provided shall be in accordance with the current BS 5266 Part 1 (or equivalent) but in terms of location and number of units it is only anticipated that two lights will be installed – one at each level to illuminate the means of escape. See page 30 for further information.</p>
<p><b>Protected Route</b></p>	<p>The protected escape route is designed to allow for residents from all parts of the building to reach the outside without passing through a higher fire risk area. The protected route MUST be kept clear of obstructions and combustible materials. The walls and ceilings to all parts of the protected route MUST be free of highly flammable materials i.e. polystyrene tiles or heavy flock wallpaper. 30 minute fire resistance as indicated in red on the plans must be provided;</p> <ul style="list-style-type: none"> <li>~ to all standard risk rooms</li> <li>~ within dwellings (including ceilings beneath attics – including the loft hatch)</li> <li>~ between dwellings (ceilings and walls)</li> <li>~ bordering the protected route</li> <li>~ including cupboards on the landing or under the stairs.</li> </ul> <p>Electric and gas meters within the protected route must be housed within a fire-resisting cupboard – see page 37. See pages 30 - 37 for technical specifications relating to fire resisting construction of walls/partitions.</p>
<p><b>Fire Doors</b></p>	<p>A fire door must be installed in each doorway leading onto the protected escape route except the bathroom/WC (30 minutes fire resistance). See page 38 for the specification for fire doors.</p>
<p><b>Security of Doors</b></p>	<p>Security devices on bedrooms and final exit doors must be capable of being opened from the inside without the use of keys, i.e. Yale type or thumb turn locks.</p>
<p><b>Fire Blankets</b></p>	<p>A fire blanket to BS 6575 (or equivalent) is to be provided in the kitchen. The blanket must be mounted on the wall 1.5m high adjacent to an exit door away from the cooking facility.</p>
<p><b>Extinguishers</b></p>	<p>Not required. If provided must be maintained in working order and residents instructed on use.</p>
<p><b>Other Recommendations</b></p>	<p>Polystyrene ceiling tiles should not be used within the premises. Portable heaters using gas cylinders or flammable liquids should not be used or stored in the premises</p>

Plan 2, House Type: Typical two storey house with cooking facilities in each let.

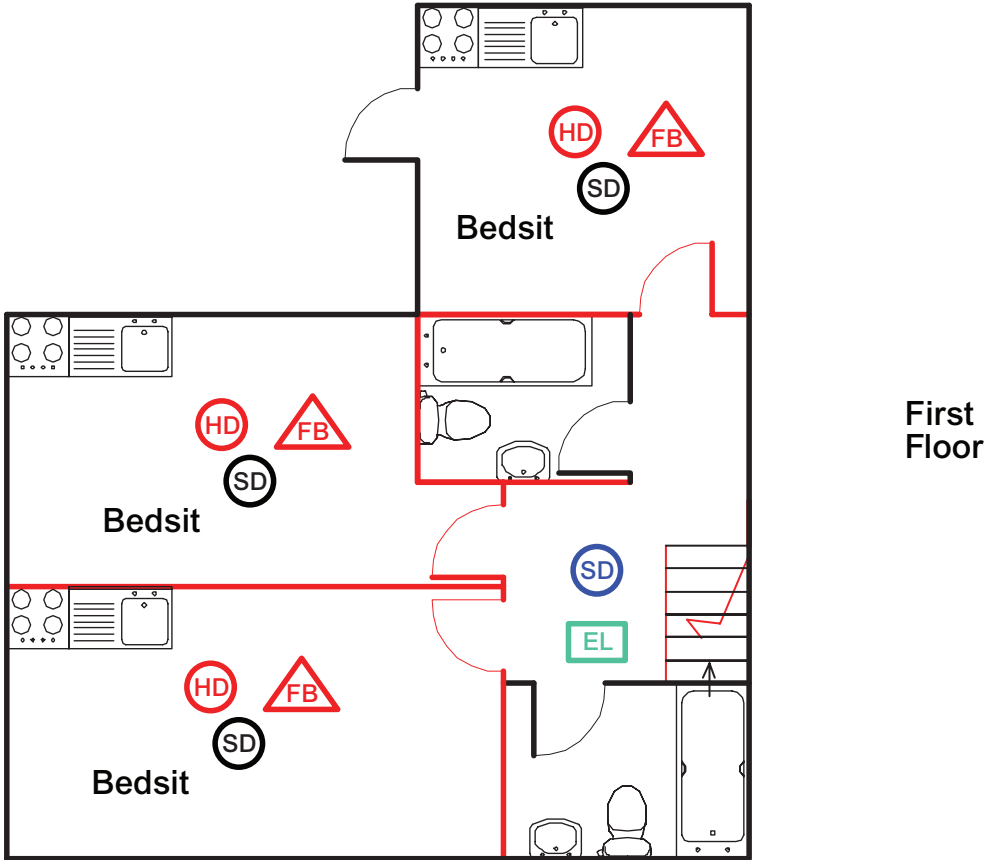
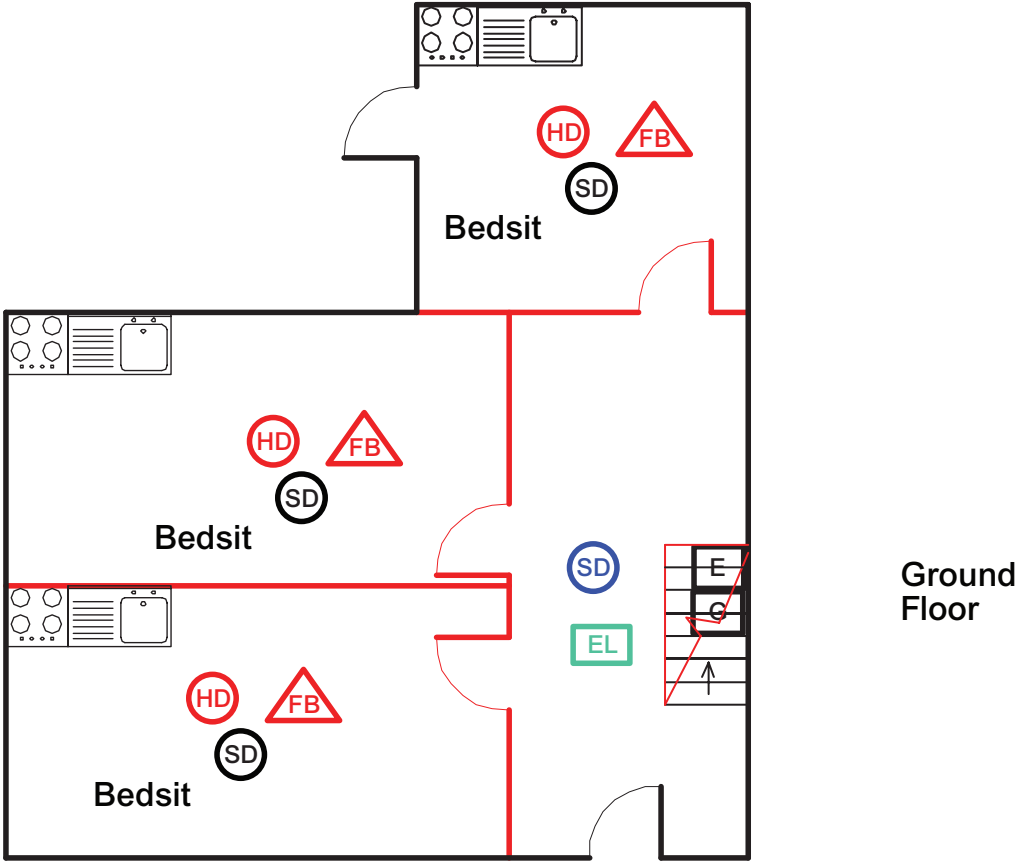

## **Outline requirements for example property - Plan 2**

<b>Detection/ Warning</b>	A system of mains powered automatic smoke detectors and heat detectors with battery back up and built in alarm to achieve BS 5839 Part 6: Grade D (or equivalent). The main system to provide heat detectors in individual lets and smoke detectors in common areas and any storerooms/cellars. All detectors must be interlinked so that if one detector is triggered, the alarm sounds in each and every alarm location. In addition, to provide an early warning to occupiers of a fire occurring within their room, a single point mains-wired smoke alarm is required, it is recommended these have a hush facility. These detectors are not interlinked between rooms. See page 26 for specification of system.
<b>Call Points</b>	Not required.
<b>Control Panel</b>	Not required.
<b>Emergency Lighting</b>	The equipment provided shall be in accordance with the current BS 5266 Part 1 (or equivalent) but in terms of location and number of units it is only anticipated that two lights will be installed – one at each level to illuminate the means of escape. See page 30 for further information.
<b>Protected Route</b>	The protected escape route is designed to allow for residents from all parts of the building to reach the outside without passing through a higher fire risk area. The protected route <b>MUST</b> be kept clear of obstructions and combustible materials. The walls and ceilings to all parts of the protected route <b>MUST</b> be free of highly flammable materials i.e. polystyrene tiles or heavy flock wallpaper. 30 minute fire resistance as indicated in red on the plans must be provided; ~ to all standard risk rooms ~ within dwellings (including ceilings beneath attics – including the loft hatch) ~ between dwellings (ceilings and walls) ~ bordering the protected route ~ including cupboards on the landing or under the stairs. Electric meters and gas meters within the protected route must be housed within a fire-resisting cupboard – see page 37. See pages 30 - 37 for technical specifications relating to fire resisting construction of walls/partitions.
<b>Fire Doors</b>	A fire door must be installed in each doorway leading onto the protected escape route except the bathroom/WC (30 minutes fire resistance). See page 38 for the specification for fire doors.
<b>Security of Doors</b>	Security devices on bedrooms and final exit doors must be capable of being opened from the inside without the use of keys, i.e. Yale type or thumb turn locks.
<b>Fire Blankets</b>	A fire blanket to BS 6575 (or equivalent) is to be provided to all rooms with cooking facilities. The blanket must be mounted on the wall 1.5m high adjacent to an exit door away from the cooking facility.
<b>Extinguishers</b>	Not required. If provided must be maintained in working order and residents instructed on use.
<b>Other Recommendations</b>	Polystyrene ceiling tiles should not be used within the premises. Portable heaters using gas cylinders or flammable liquids should not be used or stored in the premises.

**Plan 3, House Type: Typical three storey HMO with cooking in each of the lets.**

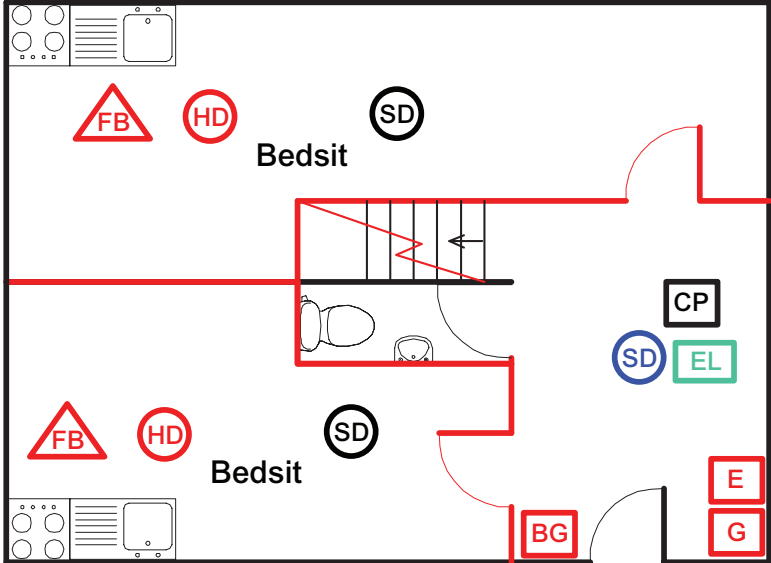

Ground Floor

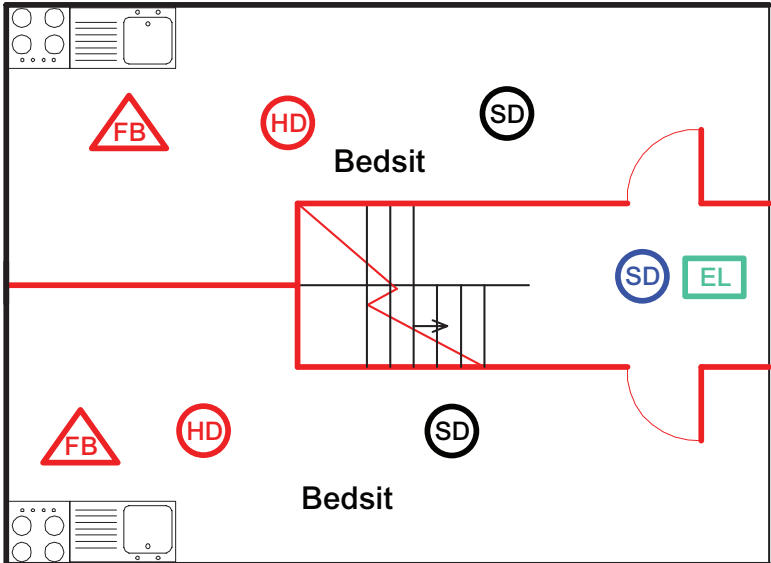

First Floor

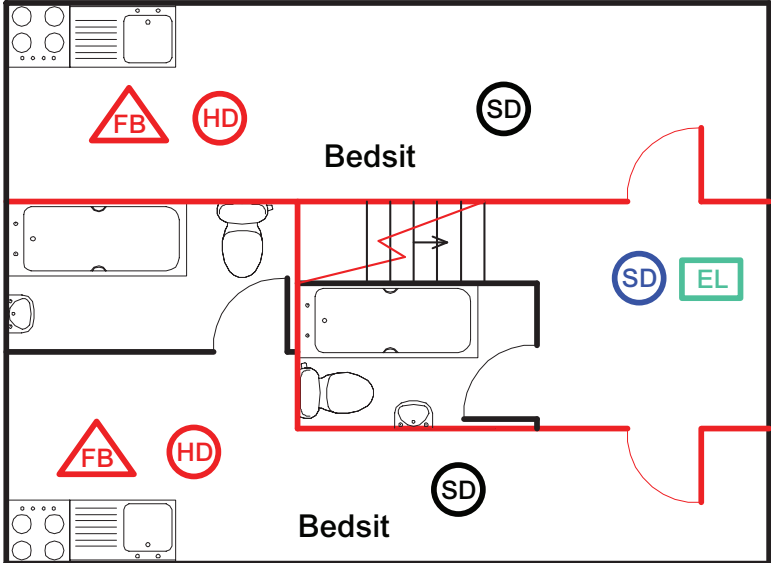

Second Floor

### **Outline requirements for example property - Plan 3**

<b>Detection/ Warning</b>	A system of mains powered automatic smoke detectors and heat detectors linked to a control panel with a built in alarm to achieve BS 5839 Part 6: Grade A (or equivalent). The main system to provide heat detectors in individual lets and smoke detectors in common areas and any storerooms/cellars. All detectors must be interlinked so that if one detector is triggered, the alarm sounds in each and every alarm location. In addition, to provide an early warning to occupiers of a fire occurring within their room, a single point mains-wired smoke alarm is required, it is recommended that these have a hush facility. These detectors are not interlinked between rooms. See page 26 for specification of system.
<b>Control Panel</b>	Must confirm to BS EN 54: Part 2. Located next to main exit door.
<b>Call Points</b>	Manual break glass call points located at each external exit from the property.
<b>Emergency Lighting</b>	To be provided in accordance with the current BS 5266 Part 1 (or equivalent) to cover the protected escape route. Location of light fittings to be determined by the design/installing engineer. See page 30 for further information.
<b>Protected Route</b>	The protected escape route is designed to allow for residents from all parts of the building to reach the outside without passing through a higher fire risk area. The protected route <b>MUST</b> be kept clear of obstructions and combustible materials. The walls and ceilings to all parts of the protected route <b>MUST</b> be free of highly flammable materials i.e. polystyrene tiles or heavy flock wallpaper. 30 minute fire resistance as indicated in red on the plans must be provided; <ul style="list-style-type: none"> <li>~ to all standard risk rooms</li> <li>~ within dwellings (including ceilings beneath attics – including the loft hatch)</li> <li>~ between dwellings (ceilings and walls)</li> <li>~ bordering the protected route</li> <li>~ including cupboards on the landing or under the stairs.</li> </ul> Electric and gas meters within the protected route must be housed within a fire-resisting cupboard – see page 37. See pages 30 - 37 for technical specifications relating to fire resisting construction of walls/partitions.
<b>Fire Doors</b>	A fire door must be installed in each doorway leading onto the protected escape route except the bathroom/WC. See page 38 for the specification for fire doors.
<b>Security of Doors</b>	Security devices on bedrooms and final exit doors must be capable of being opened from the inside without the use of keys, i.e. Yale type or thumb turn locks.
<b>Fire Blankets</b>	A fire blanket to BS 6575 (or equivalent) is to be provided all cooking facilities. The blanket must be mounted on the wall 1.5m high adjacent to an exit door away from the cooking facility.
<b>Extinguishers</b>	Not required. If provided must be maintained in working order and residents instructed on use.
<b>Other Recommendations</b>	Polystyrene ceiling tiles should not be used within the premises. Portable heaters using gas cylinders or flammable liquids should not be used or stored in the premises.

Plan 4, House Type: Typical three storey HMO with shared cooking facilities

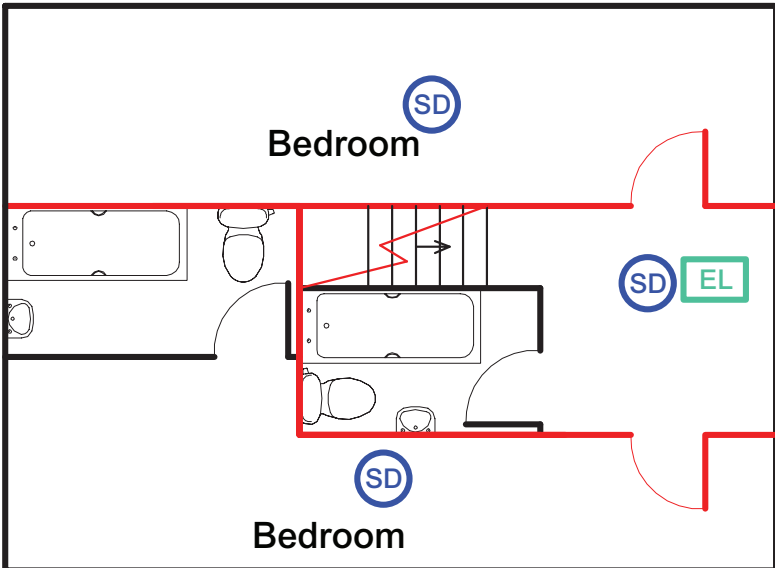
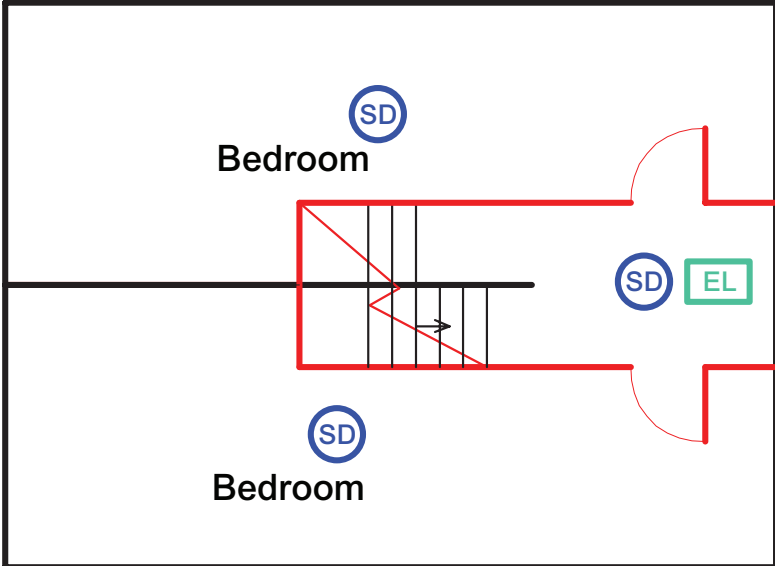
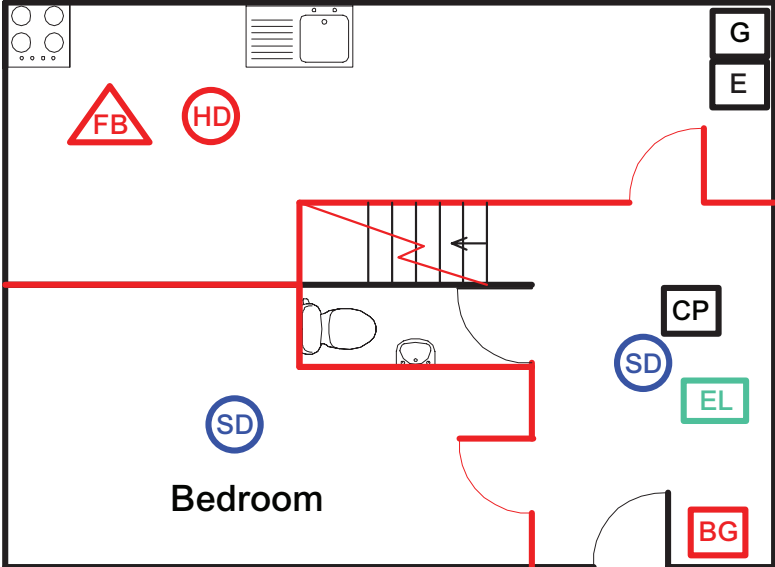

## **Outline requirements for example property - Plan 4**

<b>Detection/ Warning</b>	A system of mains powered automatic smoke detectors and heat detectors linked to a control panel with a built in alarm to achieve BS 5839 Part 6: Grade A (or equivalent). Detectors must be sited in all areas containing a fire risk. In kitchens a heat detector rather than a smoke detector must be installed. All detectors must be interlinked so that if one detector is triggered, the alarm sounds in each and every alarm location. See page 26 for specification of system.
<b>Control Panel</b>	Must conform to BS EN 54: Part 2. Located next to main exit door.
<b>Call Points</b>	Manual break glass call points located at each external exit from the property.
<b>Emergency Lighting</b>	To be provided in accordance with the current BS 5266 Part 1 (or equivalent) to cover the protected escape route. Location of light fittings to be determined by the design/installing engineer. See page 30 for further information.
<b>Protected Route</b>	The protected escape route is designed to allow for residents from all parts of the building to reach the outside without passing through a higher fire risk area. The protected route <b>MUST</b> be kept clear of obstructions and combustible materials. The walls and ceilings to all parts of the protected route <b>MUST</b> be free of highly flammable materials i.e. polystyrene tiles or heavy flock wallpaper. 30 minute fire resistance as indicated in red on the plans must be provided; <ul style="list-style-type: none"> <li>~ to all standard risk rooms</li> <li>~ within dwellings (including ceilings beneath attics – including the loft hatch)</li> <li>~ between dwellings (ceilings and walls)</li> <li>~ bordering the protected route</li> <li>~ including cupboards on the landing or under the stairs.</li> </ul> Electric and gas meters within the protected route must be housed within a fire-resisting cupboard – see page 37. See pages 30 - 37 for technical specifications relating to fire resisting construction of walls/partitions.
<b>Fire Doors</b>	A fire door must be installed in each doorway leading onto the protected escape route except the bathroom/WC (30 minutes fire resistance). See page 38 for the specification for fire doors.
<b>Security of Doors</b>	Security devices on bedrooms and final exit doors must be capable of being opened from the inside without the use of keys, i.e. Yale type or thumb turn locks.
<b>Fire Blankets</b>	A fire blanket to BS 6575 (or equivalent) is to be provided in the kitchen. The blanket must be mounted on the wall 1.5m high adjacent to an exit door away from the cooking facility.
<b>Extinguishers</b>	Not required. If provided must be maintained in working order and residents instructed on use.
<b>Other Recommendations</b>	Polystyrene ceiling tiles should not be used within the premises. Portable heaters using gas cylinders or flammable liquids should not be used or stored in the premises.

**Plan 5, House Type: Typical two storey HMO with basement.**

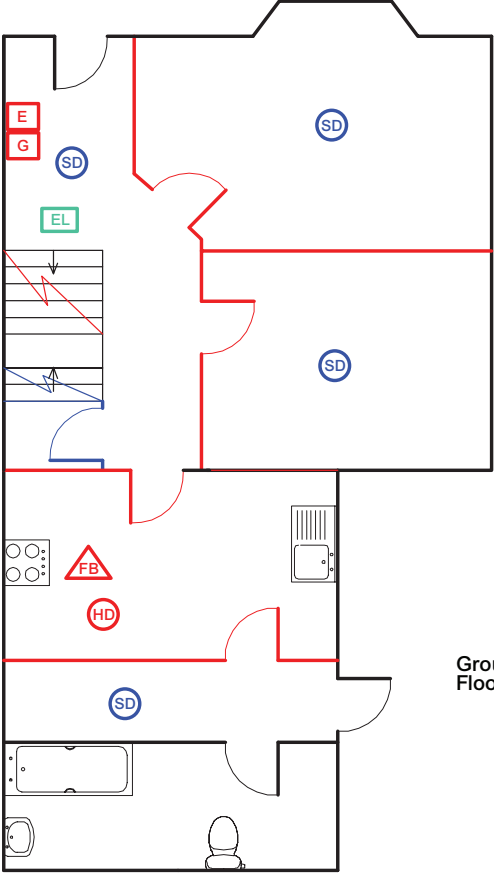

Ground Floor

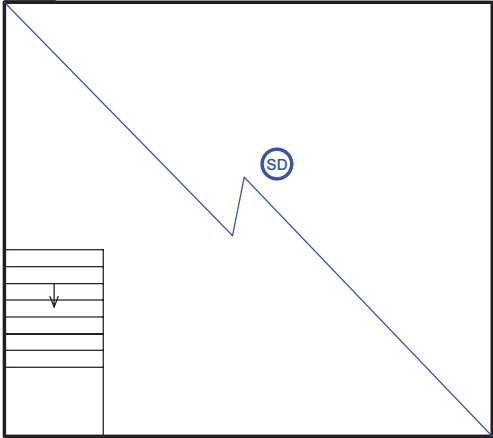

Basement

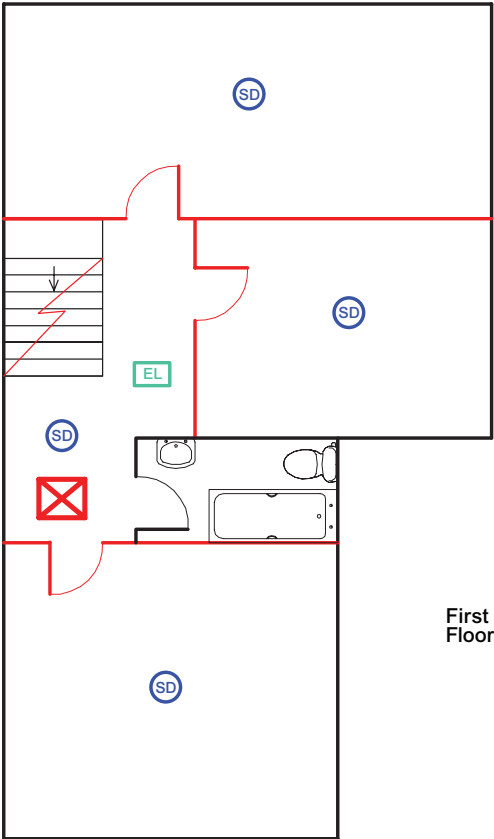

First Floor

## **Outline requirements for example property - Plan 5**

<b>Detection/ Warning</b>	A system of mains powered automatic smoke detectors and heat detectors with battery back up and built in alarm to achieve BS 5839 Part 6: Grade D (or equivalent). Detectors must be sited in all areas containing a fire risk including the basement. In kitchens a heat detector rather than a smoke detector must be installed. All detectors must be interlinked so that if one detector is triggered, the alarm sounds in each and every alarm location. See page 26 for specification of system.
<b>Call Points</b>	Not required.
<b>Control Panel</b>	Not required.
<b>Emergency Lighting</b>	To be provided in accordance with the current BS 5266 Part 1 (or equivalent) to cover the protected escape route. Location of light fittings to be determined by the design/installing engineer. See page 30 for further information.
<b>Protected Route</b>	The protected escape route is designed to allow for residents from all parts of the building to reach the outside without passing through a higher fire risk area. The protected route <b>MUST</b> be kept clear of obstructions and combustible materials. The walls and ceilings to all parts of the protected route <b>MUST</b> be free of highly flammable materials i.e. polystyrene tiles or heavy flock wallpaper. 30 minute fire resistance as indicated in red on the plans must be provided; ~ to all standard risk rooms ~ within dwellings (including ceilings beneath attics – including the loft hatch) ~ between dwellings (ceilings and walls) ~ bordering the protected route ~ including cupboards on the landing or under the stairs. ~ ceilings between basement and ground floor escape route shall provide 1 hour fire resistance as indicated in blue on the attached plans. Electric and gas meters within the protected route must be housed within a fire-resisting cupboard – see page 37. See pages 30 - 37 for technical specifications relating to fire resisting construction of walls/partitions.
<b>Fire Doors</b>	A fire door must be installed in each doorway leading onto the protected escape route except the bathroom/WC (30 minutes fire resistance). See page 38 for the specification for fire doors. The door to the basement shall provide 1 hour fire resistance.
<b>Security of Doors</b>	Security devices on bedrooms and final exit doors must be capable of being opened from the inside without the use of keys, i.e. Yale type or thumb turn locks.
<b>Fire Blankets</b>	A fire blanket to BS 6575 (or equivalent) is to be provided in the kitchen. The blanket must be mounted on the wall 1.5m high adjacent to an exit door away from the cooking facility.
<b>Extinguishers</b>	Not required. If provided must be maintained in working order and residents instructed on use.
<b>Other Recommendations</b>	Polystyrene ceiling tiles should not be used within the premises. Portable heaters using gas cylinders or flammable liquids should not be used or stored in the premises.

**Plan 6, House Type: Typical three storey HMO above commercial premises with cooking facilities in each let**

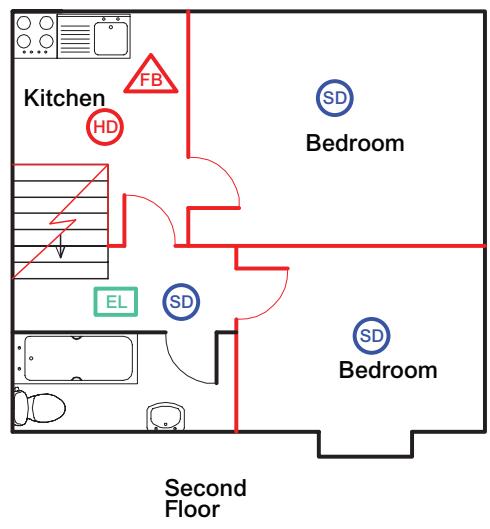
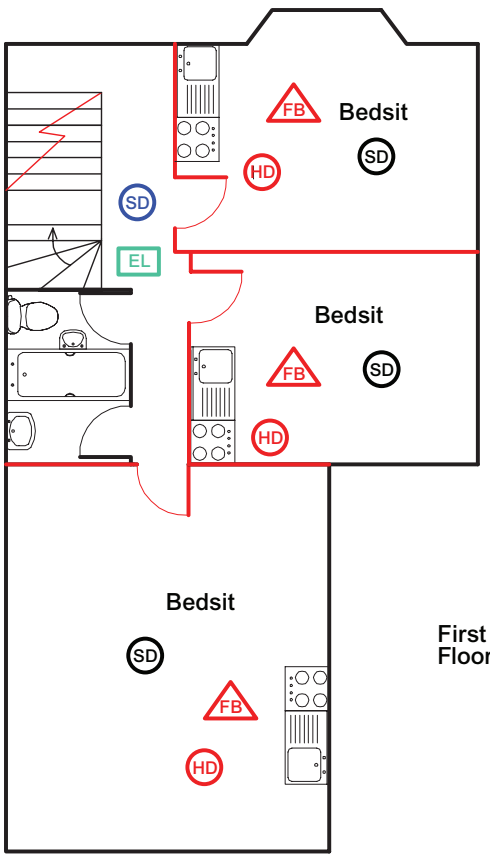
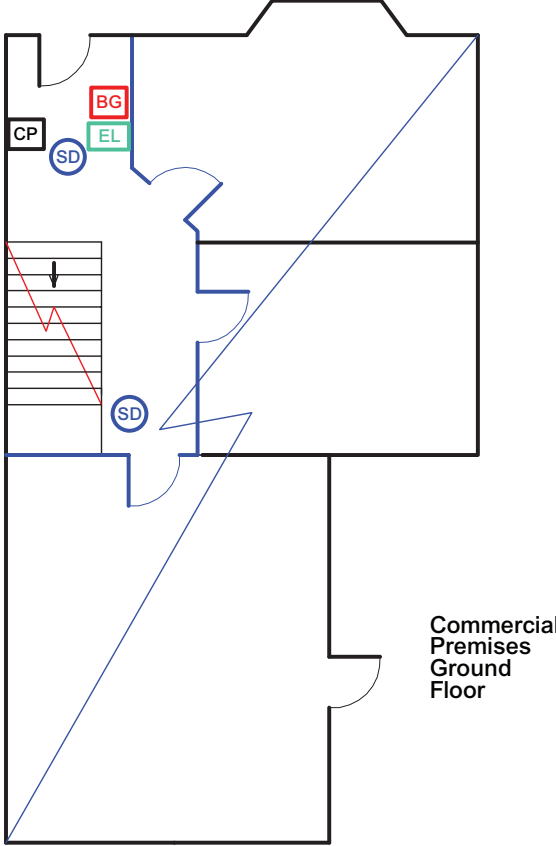

## **Outline requirements for example property - Plan 6**

<b>Detection/ Warning</b>	A system of mains powered automatic smoke detectors and heat detectors linked to a control panel with a built in alarm to achieve BS 5839 Part 6: Grade A (or equivalent). The main system to provide heat detectors in individual lets and smoke detectors in common areas and any storerooms/cellars. All detectors must be interlinked so that if one detector is triggered, the alarm sounds in each and every alarm location. In addition, to provide an early warning to occupiers of a fire occurring within their room, a single point mains-wired smoke alarm is required, it is recommended that these have a hush facility. These detectors are not interlinked between rooms. See page 26 for specification of system.
<b>Control Panel</b>	Must confirm to BS EN 54: Part 2. Located next to main exit door.
<b>Call Points</b>	Manual break glass call points located at each external exit from the property.
<b>Emergency Lighting</b>	To be provided in accordance with the current BS 5266 Part 1 (or equivalent) to cover the protected escape route. Location of light fittings to be determined by the design/installing engineer. See page 30 for further information.
<b>Protected Route</b>	The protected escape route is designed to allow for residents from all parts of the building to reach the outside without passing through a higher fire risk area. The protected route <b>MUST</b> be kept clear of obstructions and combustible materials. The walls and ceilings to all parts of the protected route <b>MUST</b> be free of highly flammable materials i.e. polystyrene tiles or heavy flock wallpaper. 30 minute fire resistance as indicated in red on the plans must be provided; <ul style="list-style-type: none"> <li>~ to all standard risk rooms</li> <li>~ within dwellings (including ceilings beneath attics – including the loft hatch)</li> <li>~ between dwellings (ceilings and walls)</li> <li>~ bordering the protected route</li> <li>~ including cupboards on the landing or under the stairs.</li> <li>~ ceilings and walls between commercial and residential shall provide 1 hour fire resistance as indicated in blue on the attached plans.</li> </ul> Electric and gas meters within the protected route must be housed within a fire-resisting cupboard – see page 37. See pages 30 - 37 for technical specifications relating to fire resisting construction of walls/partitions.
<b>Fire Doors</b>	A fire door must be installed in each doorway leading onto the protected escape route except the bathroom/WC (30 minutes fire resistance). Fire door separating the commercial from the residential areas shall provide one hour fire resistance. See page 38 for the specification for fire doors.
<b>Security of Doors</b>	Security devices on bedrooms and final exit doors must be capable of being opened from the inside without the use of keys, i.e. Yale type or thumb turn locks.
<b>Fire Blankets</b>	A fire blanket to BS 6575 (or equivalent) is to be provided in the kitchen. The blanket must be mounted on the wall 1.5m high adjacent to an exit door away from the cooking facility.
<b>Extinguishers</b>	Not required. If provided must be maintained in working order and residents instructed on use.
<b>Other Recommendations</b>	Polystyrene ceiling tiles should not be used within the premises. Portable heaters using gas cylinders or flammable liquids should not be used or stored in the premises.

## **Part 5 - Maintenance of Fire Protection**

Once the fire precautions have been installed, the owner and the residents both have responsibility for their maintenance. There are other management duties imposed on managers of HMOs and full information regarding these can be sought from your Local Authority.

### **Owner's Responsibility**

The owner must make sure the structural fire precautions, the fire alarm system, and other equipment are maintained in good condition and proper working order.

#### **The Fire Alarm System**

The owner or manager must be familiar with how the fire alarm system operates and know how to recognise and remedy faults. The alarm installer will have provided an operator's manual and a contact telephone number. It is very important that faults are reported and remedied immediately.

A BS 5839 Part 6 Grade A (or equivalent) system with a control panel (in properties of 3 or more storeys) must be checked and serviced regularly by a qualified electrician or alarm engineer. This British Standard also calls for regular tests of different call points. Records of the checks carried out should be kept for future reference in the book provided by the installer or similar. An example record sheet is included in Part 7 of this document.

A BS 5839 Part 6 Grade D (or equivalent) system (without a control panel) can be checked by carrying out the following actions:-

- The alarm system should be tested, by checking that all alarms activate simultaneously and air intake grilles should be cleared of dust, insects and cobwebs.
- Back-up batteries should be replaced when necessary, in line with the manufacturer's recommendations.

This should be carried out monthly and a written record kept. The detector should be replaced after ten years.

#### **Emergency Lighting**

This should be tested monthly and records of the checks kept. Some systems need the electrical supply to be switched off for three hours, so that the internal batteries can be completely discharged (this helps to prolong the life of the batteries).

#### **Fire Doors**

These should be checked regularly to ensure that the doors and frames are undamaged and that self-closing devices work properly. The smoke seals to the doors must be undamaged and form a good seal between the door and frame, it is important not to paint over smoke seals.

#### **Fire Blankets and Extinguishers**

If provided, these should be checked to make sure they are in place and available for use. Extinguishers must be tested on an annual basis, and in accordance with the manufacturer's instructions, a record of these test should be provided by the engineer.

#### **Escape Routes**

Routes should be checked regularly to make sure they are clear from obstruction and free from combustible materials and there are no trip or slip hazards, such as loose carpet.

**Part 7 of this document gives an example sheet for you to record all your routine checks. It is strongly recommended that you use this or something similar to demonstrate your on-going management and maintenance of the property.**

### **Informing Residents about Fire Protection**

Existing residents should be informed about the fire protection system as soon as it is installed, and new residents should be informed as soon as they move in.

All residents should know:

- what the fire alarm is for and how to recognise the sound;
- what the escape route is; a practice fire drill is a good idea; and,
- the importance of not propping open fire doors or interfering with the alarm system.

### **Residents' Responsibility**

Residents must allow the owner reasonable access to the accommodation to carry out checks on fire precautions and must comply with reasonable instructions given to them by the landlord.

Residents must not interfere with the fire protection system and equipment, for example, by:

- removing safety equipment;
- propping fire doors open;
- covering or removing smoke detectors; or,
- blocking escape routes with furniture, bicycles or rubbish etc.

A template leaflet/poster for you to display in your property may be available from your Local Authority.

## **Part 6 Technical Specifications**

### **6A: Automatic Fire Detection and Alarm Systems**

**Fire Alarm System to Comply with Current British Standard 5839 Part 6: Grade A (or equivalent), LD2 category coverage\*.**

#### **General**

1. This comprises a system of electrically operated smoke and/or heat detectors, which are linked to a control panel to give information on the location of the fire or any fault, which may develop.

#### **Control Panel**

2. The control panel must conform to current BS EN 54: Part 2.

#### **Call Points**

3. These systems will normally incorporate manual break glass call points, located on each floor and at the final exit. The provision of break glass call points and their suitability should be assessed as part of the premises risk assessment.

\* This document and your local Authority will generally not require the installation of call points on every level. You should however be aware that the alarm system will not comply fully with the BS.

#### **Audibility**

4. The alarm signal must achieve sound levels of: -
  - Not less than 65dB (A) in all accessible parts of the building.
  - Not less than 75dB (A) at all bed heads, to arouse sleeping persons when all doors are shut.

It is the responsibility of the installation contractor to specify the appropriate number and location of alarm sounders to achieve these sound levels.

#### **Power Supplies**

5. The power supply for a Grade A system should be a dedicated circuit, segregated from other electric circuits by distance, conduit, trunking or cable type. The system must have a 72 hour battery back up.

The circuit should have its own switch/fuse close to the origin of the supply, which must be labelled with its function.

#### **Wiring**

6. The wiring should be of fire resisting cable or protected from fire by 30 minute construction and should be monitored to give warning at the control panel in the event of open or short circuit.

**Fire Alarm System to Comply with Current British Standard 5839 Part 6: Grade D (or equivalent), LD2 category coverage.**

**General**

1. This comprises a system of one or more interlinked mains powered smoke and/or heat detectors each with an integral stand by battery and built in alarm.

**Control Panel**

2. A control panel is not required with this system.

**Call Points**

3. Call points are not required on a Grade D system.

**Audibility**

4. The alarm signal must achieve sound levels of: -
  - Not less than 65dB (A) in all accessible parts of the building
  - Not less than 75dB (A) at all bed heads, to arouse sleeping persons when all doors are shut.

It is the responsibility of the installation contractor to specify the appropriate number and location of alarm sounders to achieve these sound levels.

**Power Supplies**

5. The power supply for a Grade D system should be a dedicated circuit or be connected to a regularly used, electrically protected, local lighting circuit. All smoke alarms and heat detectors should be connected to the same final circuit. The system must have a 72 hour battery back up.

**Wiring**

6. Wiring should comply to IEE Regulations (BS 7671).

## General Requirements Common to Both Systems

### ■ What type of smoke detector?

There are three types of smoke detector currently on the market – ionisation, optical and combined. Optical detectors are generally more sensitive than ionisation for slow burning, smoldering fires that would be typical from foam filled upholstery. You should therefore opt to install optical or combined (detect smoldering and flaming fires) smoke detectors unless for instance a shower is present in the room. Further guidance can be sought from your installer and your Local Authority.

### ■ Mounting Position

Smoke/heat detectors should preferably be mounted on ceilings and should be located at least 300mm horizontally from any wall/beam or light fitting.

### ■ Obstructions

If the passage of smoke or hot gases to a detector is likely to be disturbed by a ceiling obstruction (such as a beam) having a depth greater than 150mm, then detectors should be provided on each side of the obstruction.

### ■ Power Supply

The power supply to the fire detection system must be taken from the landlord's supply. Coin/token meters are not acceptable on electrical systems that power the alarms.

### ■ Mixed Use Buildings

Where there is a mixture of residential and commercial use within the same building, the fire alarm system may be required to be installed in accordance with the current British Standard 5839 Part 1 (or equivalent). *Contact your Local Authority for further advice in these circumstances.*

### ■ Certification

Fire alarm systems must be installed by a suitably qualified electrical contractor. Upon completion, the contractor must provide an installation, commissioning and test certificate (see model certificate on next page).

# Model Installation, Commissioning and Test Certificate

Model certificate for Grades B, C, D, E and F systems



This certificate is not valid if the serial number has been defaced or altered

FHN2 (B-F)/

TRACEABLE SERIAL NUMBER

## CERTIFICATE OF DESIGN, INSTALLATION AND COMMISSIONING OF A FIRE DETECTION AND ALARM SYSTEM OF GRADE B, C, D, E OR F IN A DWELLING

Original (to the person or organisation doing the work)

DETAILS OF THE CLIENT		Issued in accordance with BS 5839-6:2004.
Client:		
Address:		

DETAILS OF THE FIRE DETECTION AND ALARM SYSTEM		The system is
Address:		
Extent of the fire detection and alarm system covered by this certificate	<input type="checkbox"/> New <input type="checkbox"/> An addition <input type="checkbox"/> An alteration	

DESCRIPTION OF SYSTEM GRADE AND SYSTEM CATEGORY		Tick boxes as appropriate
System grade	<input type="checkbox"/> B <input type="checkbox"/> C <input type="checkbox"/> D <input type="checkbox"/> E <input type="checkbox"/> F	System category: <input type="checkbox"/> LD1 <input type="checkbox"/> LD2 <input type="checkbox"/> LD3 <input type="checkbox"/> PD1 <input type="checkbox"/> PD2

COMMISSIONING		See Note 1	A tick in the box indicates the inspection or test has been performed and the results are satisfactory. N/A indicates an inspection or test is Not Appropriate
Test buttons checked	<input type="checkbox"/>	Simulated smoke or aerosol test	<input type="checkbox"/>
All alarm warning devices operate	<input type="checkbox"/>	Heat test	<input type="checkbox"/>
Silencing system checked	<input type="checkbox"/>	Bedroom sound level (Clause 13.2)	<input type="checkbox"/>
		Dedicated circuit(s) provided	<input type="checkbox"/>
		Protective device labelled	<input type="checkbox"/>
		Audible and visual indication of mains failure	<input type="checkbox"/>
		Sound level test instrument used	See Note 2
		Model and serial No.	
		Serial No. of associated Electrical Installation Certificate or Minor Electrical Installation Works Certificate (See Note 1)	

USER INSTRUCTIONS		Tick boxes to indicate that the written information has been issued to the user	
I/We the undersigned declare that the occupier* of the dwelling (or owner in the case of a house in multiple occupancy) has been provided with written information about essential aspects of the operation and maintenance of the system, as follows:			
Operation of the system	<input type="checkbox"/>	Routine testing of the system	<input type="checkbox"/>
Action to be taken in the event of a fire alarm signal	<input type="checkbox"/>	Servicing and maintenance of the system (including intervals at which any batteries should be replaced)	<input type="checkbox"/>
Avoidance of false alarms and action in the event of a false alarm	<input type="checkbox"/>	The need to keep clear space around all detectors and manual call points	<input type="checkbox"/>
Warning that apparent false alarm from carbon monoxide detector may not be false alarm	<input type="checkbox"/>	Special precautions relevant to any lithium batteries used in the system	<input type="checkbox"/>
		Checking the system on reoccupation of the dwelling after a vacation etc.	<input type="checkbox"/>
		The need to avoid contamination of detectors by paint	<input type="checkbox"/>
		As-fitted drawing	<input type="checkbox"/>
		* In the case of a newly-built property and where the future occupier is unknown, the User Instructions should be issued to the builder for onward transmission to the purchaser together with their related electrical safety certificate.	

CERTIFICATION OF DESIGN, INSTALLATION AND COMMISSIONING	
I/We, being the person(s) responsible (as indicated by my/our signature(s) below), for the design, installation, and commissioning of the fire alarm system, particulars of which are set out above, CERTIFY that the said work for which I/we have been responsible complies to the best of my/our knowledge and belief with the recommendations of BS 5839: Part 6 for the system described above, except for the variations, if any, stated below:	
Variations (if any):	
The extent of liability of the signatory is limited to the work described above as the subject of this certificate.	
For the DESIGN, INSTALLATION AND COMMISSIONING of the system:	This certificate has been reviewed by the Qualified Supervisor:
Signature: _____ Date: _____	Signature: _____ Date: _____
Name (CAPITALS): _____	Name (CAPITALS): _____

DETAILS OF THE APPROVED CONTRACTOR	
Trading Title:	
Address:	
Postcode:	
NICEIC Enrolment No (Essential information):	_____
Branch number (if applicable):	_____

Note 1. The electrical safety aspects of the fire detection and alarm system must also be certified in accordance with BS 7671: 'Requirements for Electrical Installations' by issuing an electrical safety certificate of a form which meets the requirements of BS 7671, such as a 'Domestic Electrical Installation Certificate' or, where appropriate, a 'Minor Electrical Installation Works Certificate'.

Note 2. An instrument complying with BS EN 61672, Class 2, with slow response and A weighting (see Clause 13.2) is suitable for measuring the sound level.

Note 3. This certificate may be required by an authority responsible for enforcement of the safety legislation, such as the building control authority or housing authority. The recipient of this certificate might rely on the certificate as evidence of compliance with legislation. Liability could arise on the part of any organisation or person that issues a certificate without due care in ensuring its validity.

Please see the 'Notes for Recipient' on the reverse of this page.

## **6B: Emergency Lighting**

### **Provision of an Emergency Lighting System to comply with parts of Current British Standard 5266 Part 1 (or equivalent)**

This is a system of battery-powered lights, where the battery is continuously trickle charged from the mains supply. The lights are to be located on the fire escape route and are designed to operate if the local primary lighting sub-circuit fails, via a relay switch. The wiring should be carried out in twin and earth cable and power must be taken directly from the landlord's supply. A qualified electrical contractor must carry out the installation. Upon completion, the contractor must provide an appropriate certificate. The system must have a suitable means for simulating failure of the normal supply so that you can test the system. It will not normally be necessary to install emergency lighting in all the locations required by the BS 5266, but the lighting should cover changes in direction and level.

**Note: For certain 2 storey properties (for example) where there is borrowed light and no back addition emergency lighting may not be necessary, this will be determined on a risk basis. If you have any queries please contact your Local Authority.**

## **6C: Signs and Notices**

Where the property has an unusual layout you may be required to display exit signs, your Local Authority will advise you on this. If you decide to or are required to display signs they should meet the following specification:

Clearly visible 'EXIT' exit signs comprising white figures on a green background should be provided within the stairwell at each landing level to clearly indicate the escape route from the building Size 100mm x 500mm to comply with The Health and Safety (Safety Signs and Symbols) Regulations 1996. Exit signs above final exit doors shall be provided above alternative exit doors, for example above the rear door from the kitchen.

## **6D: Fire Resistance Of Walls And Partitions**

### **Half Hour Resistance**

#### **1. New Walls And Partitions**

Half hour fire resistance can be achieved by any of the following methods of construction:

#### **Solid walls**

- Masonry blockwork/brickwork 100mm thick (load bearing)
- Masonry blockwork/brickwork 75mm thick (non-load bearing)

#### **Stud Partitions**

The constructions given below apply to both faces of the wall or partitioning. They are also suitable for infilling spandrels to staircases providing adequate studding has been incorporated into the wall:-

Partition walls to consist of a timber frame 75mm x 50mm minimum (non-loading bearing) with head and sole plates, studs at 600mm centers and facing each side of:-

- 12.5mm plasterboard finished with plaster skim
- 12.5mm fire rated plasterboard, unplastered
- Proprietary fire resisting insulation board installed in accordance with manufacturers specifications. **(See Diagram 1)**

#### **Manufactured Partitions**

Proprietary cellular core partition e.g Paramount board or equivalent installed in accordance with manufacturers specifications.

#### **Note:**

In all cases, where partition walls are to be left unplastered, the joints must be taped and filled using joint compound as recommended by the board manufacturer. Any gaps between the wall and surrounding structure should be filled flush using suitable fire resisting jointing compound.

## Diagram 1

### Example of fire resisting partitions

(half hour fire resistance)

The studding framework should be 75mm x 50mm and should be securely fixed where it joins floor, adjacent walls and true ceilings.

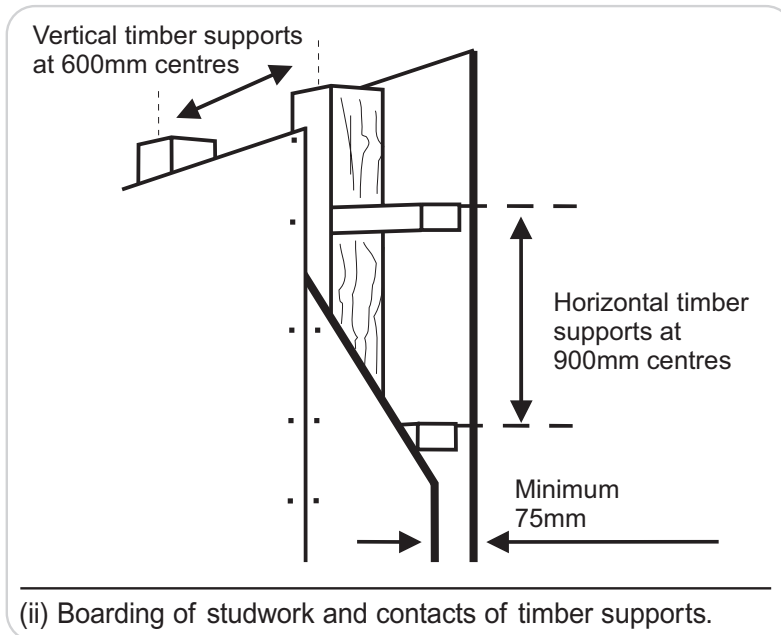
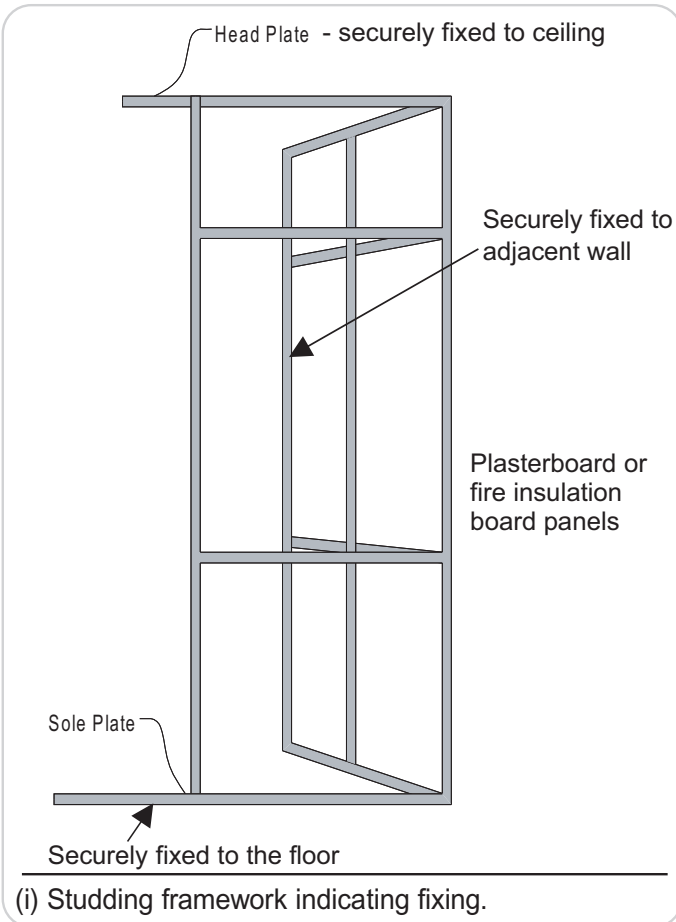

## 2. Upgrading Existing Lath and Plaster Partitions to Achieve Half Hour Fire Resistance

The condition of the lath and plaster partition must be examined in detail. Retention of the partition surfaces must only be considered if in good condition and there is no loose or failing plaster.

In the event of minor damage or inconclusive investigation of the partition construction, the partition must be upgraded on the risk side (room side) by replacing the lath and plaster or by overboarding it with 12.5mm gypsum wallboard or fireline board fixed with galvanized clout/plasterboard nails. These should have sufficient length to penetrate the lath and plaster and provide a firm fixing in the timber framework. The partition should be finished by scrimming and skimming with plaster.

### One hour fire resistance

**The following forms of Construction will provide 60 minutes fire resistance to Walls and Partitions**

#### **A: New Walls and Partitions**

##### **Solid masonry wall**

- Masonry blockwork/brickwork 100mm thick (load bearing)
- Masonry blockwork/brickwork 75mm thick (non-load bearing)

##### **Stud partitions**

75 x 50mm timber load-bearing/non load-bearing stud partition. Studs at 600mm centres and no infill with the following facings on **both sides**.

- 2 x 12.5mm **Gypsum Wallboard** fixed with 40mm (1st layer) and 50mm (2nd layer) galvanised nails to every timber support at 150mm centres. The joints to be staggered, then taped and filled or surface scrimmed and skimmed.
- 15mm **Fire Resistant Gypsum Wallboard** (provided studs are 100mm x 50mm) fixed with 50mm galvanised nails to every timber support at 150mm centres. The joints to be taped and filled or surface scrimmed and skimmed.
- 9mm Supalux fillets, 75mm wide fixed to face of studs, 2 layers of 9mm Supalux, joints staggered with 50mm nails at 300mm centres. Fillets not required if partition is non load-bearing).
- Expanded metal lathing to BS 1369: Part 1: 1987 securely fixed to the timber studs. Plaster with 13mm lightweight Gypsum metal lathing type.

Where it is not possible to fix a facing on **both sides** of the partition, then **specifications 1 or 2** below can be used.

The specifications concern a non-load-bearing solid construction, which will provide a fire resistance of 60 minutes. They should only be used in constructions of up to 3 metres in height.

#### **Specification 1**

The partition consists of one layer of 20mm Supalux and one layer of 15mm Supalux. Vertical board joints are staggered nominally half the board width (i.e. typically 610mm) between the layers and the horizontal joints staggered by at least 300mm between layers.

32mm x 32mm x 20 gauge continuous mild steel angles are to be fixed with 32mm No 8 screws at 300mm centres into non-combustible plugs.

Fix 20mm Supalux to the angles with 32mm No 8 self-tapping screws at 300mm centres.

Fix the two layers together with 32mm No 8 self-tapping screws at 300mm centres on both sides of the horizontal and vertical joints.

## Specification 2

Fix 25mm x 50mm x 0.8mm galvanised steel perimeter angle secured to the perimeter using steel screws or bolts and plugs at 500mm centres.

Fix 30mm self-drilling/tapping screws at 200mm centres. Secure 20mm layer of New Tacfire to perimeter angle.

Fix 35mm self-drilling/tapping screws at 300mm centres. Secure 15mm layer of New Tacfire to the first layer, around the perimeter and down the centre of each board.

Any joints in New Tacfire boards must be staggered by at least 350mm.

## Existing Partitions

The following methods can be used to upgrade an existing (lath and plaster) partition made up of 75mm x 50mm timber studs which is either load-bearing or non load-bearing. The studs at maximum 600mm centres with no infill to provide a partition with 60 minute fire resistance, which upgraded.

Partitions can be upgraded in one of two ways:

By the provision of an additional board to the existing facing **on both sides**:

9mm Supalux fixed, on each side of the partition, using 63mm nails or screws at 300mm centres.

12mm New Tacfire fixed, on each side of the partition, using screws at 300mm centres. The length of the screws should be such that they penetrate 38mm into the stud.

By the provision of a cavity infill:

In this case it must be a non-load-bearing stud partition made up of minimum 89mm x 38mm studs at 600mm centres with no infill and covered with 12.5mm plasterboard.

Take off one face of the existing partition. Fill the cavity between the studs with 90mm Rockwool Timberbatts of density 23Kg/m<sup>3</sup>. Provide 12.5mm Gypsum Wallboard fixed at 150mm centres with 38mm galvanised nails. Joints must be taped and filled or surface scrimmed and skimmed.

Alternatively, if the timber studs are minimum of 100mm x 38mm at 600mm centres and covered with 12.5mm plasterboard the cavity between the studs can be filled with 100mm Rockwool RW2 slabs.

**Any variations or alternatives to the above specifications must be agreed with your Local Authority prior to the works being carried out.**

## 6E: The Upgrading of Floors and Ceilings

The floor and ceiling construction between floor levels in any house in multiple occupation must be able to resist the spread of smoke and flame from any fire.

### 1/2 Hour Fire Resistance

Confirm construction to be a minimum of 25mm square edge softwood boarding on 75mm x 50mm (7" x 2") softwood joists under drawn with 16mm (3/8") lath and plaster in sound condition. Over lay all floorboards above ground floor with minimum 4mm dense hardboard to total floor area.

**Further information is available in Building Research Establishment Digest 208,**

**“Increasing the Fire Resistance of Existing Timber Floors.”**

Other specifications are available and reference can be made to manufacturers' detailed specifications if supported by detailed fire test documentation.

### One Hour Resistance

The Following Forms of Construction will provide 60 minutes Fire Resistance to ceilings

#### **New Ceiling**

The following boards when fixed to timber joists of minimum size 150mm x 50mm at max. 600mm centres with no infill and plain edged floorboards will provide 60 minutes fire protection.

- 2 x 15mm (or 12.5mm + 19mm) **Gypsum Wallboard** fixed with 50mm (1st layer) and 65mm (2nd layer) galvanised nails to every timber support at 150mm centres. Timber support includes the joists and minimum 38mm x 38mm noggins to span between the joists to support the board edges. The joints are to be staggered, then taped and filled or surface scrimmed and skimmed. The plain edge floorboards are to be overlaid with 3.2mm hardboard.
- 2 x 12.5 **Fire Resistant Gypsum Wallboard** fixed with 40mm (1st layer) and 50mm (2nd layer) galvanised nails to every timber support at 150mm centres. Timber support includes the joists and minimum 38mm x 38mm noggins to span between the joists to support the board edges. The joints to be staggered, then taped and filled or surface scrimmed and skimmed.
- 2 x 12mm Supalux, joints staggered, fixed with 63mm x No 8 screws at 300mm centres. Existing plain edge floorboard is to be overlaid with 4.8mm hardboard.

#### **Existing ceilings**

The following methods can be used to upgrade an existing (lath and plaster) ceiling made up of plain edge floorboards nailed to joists of minimum size of 150mm x 50mm at 600mm centres with no infill to provide a ceiling with 60 minutes fire resistance.

Ceilings can be upgraded in one of two ways:-

- By the provision of additional protection below the existing surface (i.e. room side)
- By the provision of additional protection above the existing ceiling i.e. within the floor space.

It is essential to ensure that if the existing ceiling is to be retained and upgraded, particularly if additional protection is to be provided within the floor space, that any gaps in the structure are properly sealed.

### ■ Protection below the Existing Ceiling

The plain edge boards are to be overlaid with 3.2mm hardboard. The existing ceiling is to be supported by chicken wire or expanded metal lathing of 25mm mesh, securely nailed to the joists. 38mm x 38mm noggins must also be fixed to span between the battens to support the following board edges:-

Two layers of 12.5mm **Fire Resistant Gypsum Wallboard** joints staggered.

or

Two layers of 10mm Glasroc Multi-Board with joints staggered.

The plain edge floorboards are to be overlaid with 4.8mm hardboard. The existing ceiling is supported with chicken wire or expanded metal securely fixed to the joists. 12mm Supalux is fixed through the existing ceiling to the joists with 63mm x No 8 wood screws at 300mm centres.

The plain edge boards are to be overlaid with 3.2mm hardboard. The existing ceiling is to be under-drawn with expanded metal lathing to BS 1369: Part 1: 1987 securely nailed to the joists. Plaster with 13mm (from face to lath) lightweight Gypsum metal lathing type.

### ■ Protection above the existing ceiling

Take up, as necessary, the existing floorboards. Fix 100mm x 12.5mm thick strips of Glasroc Multi-Board to each side of the joists using 36mm Gyproc Drywall screws at 300mm centres. Lay 12.5mm Glasroc Multi-Boards on top of the strips. Relay the floorboards. Overlay the floorboards with 3.0mm hardboard.

Take up, as necessary, the existing floorboards. Lay 19mm Gypsum metal lathing plaster trowelled between the joists in conjunction with expanded metal lathing or chicken wire at mid thickness of the plaster and well turned up and fixed to the joist sides or continuous over the joists. To prevent staining polythene sheets should be laid on the back of the existing ceiling. Relay the floorboards. Overlay the floorboards with 3.2mm hardboard.

Take up, as necessary, the existing floorboards. Fix 2 x 75mm x 12mm Supalux strips to each side of the joists with 50mm x No 8 screws. Lay 12mm Supalux cut, to be a tight fit, between the joists on top of the strips. Superlux to be overlaid with 80mm x 20Kg/m<sup>3</sup> Rockwool Rollbatts. Relay the floorboards. Overlay the floorboards with 4.8mm hardboard.

Great care needs to be taken at the junctions between floors and walls, particularly where the floor construction is to be upgraded by providing additional protection within the floor space. The gap should be sealed between the adjacent joist and partition wall and the gap between the floorboards and skirting boards with **intumescent** paste.

For guidance on achieving 1-hour fire resistance to suspend ceilings, advice should be sought from an Environmental Health Officer.

**Any variations or alternatives to the above specifications must be agreed with your Local Authority prior to the works being carried out.**

## Fire Resisting Glazing in Walls and Partitions

For the purpose of this document glazing can be used to give periods of fire resistance of up to one hour, the actual fire resistance is determined by the nature and dimensions of the glass, the type of frame and method of securing the glass.

The limitations on the use of uninsulated fire-resisting glazing for Building Regulation purposes are described below and it should be noted in this case that uninsulated fire-resisting glazing is not permitted between residential/sleeping accommodation and a protected corridor or lobby.

Wired glass should not be used in panes exceeding 1.2msq in area and should be 6mm thick for half hour fire resistance.

The design data for wired glazing in different frames is set out below and is applicable to glazed areas in walls and partitions.

The timber frame members and dividing bars should not be less than 56 mm deep and 44 mm wide with the rebate worked from the solid material. For the protection of timber beading intumescent paints have proved satisfactory.

See diagram 2 below for methods of fixing.

### Method of fixing for Glazing in Walls and Partitions

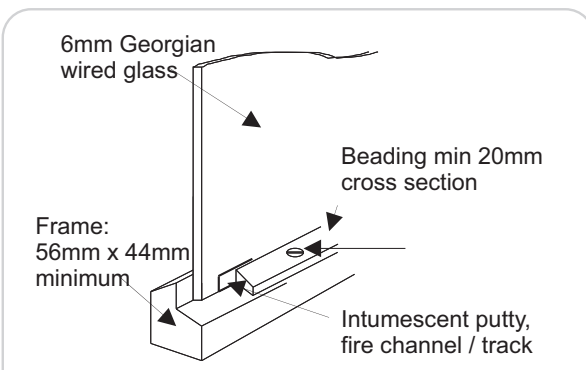

(i) Three dimensional view of glazed panel/window

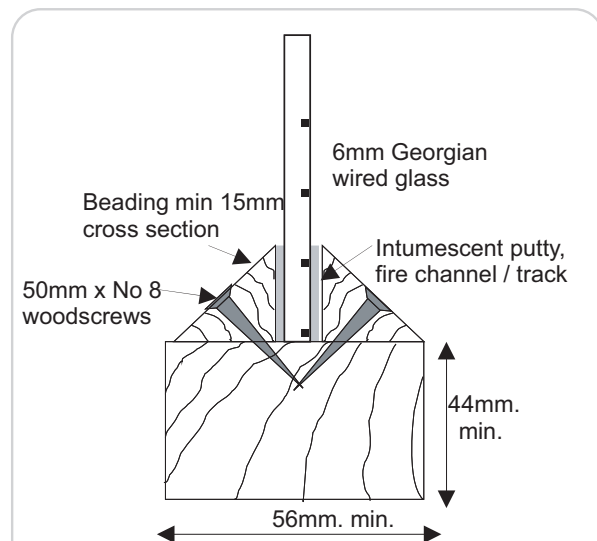

(ii) Cross section of glazed panel with glazing positioned centrally

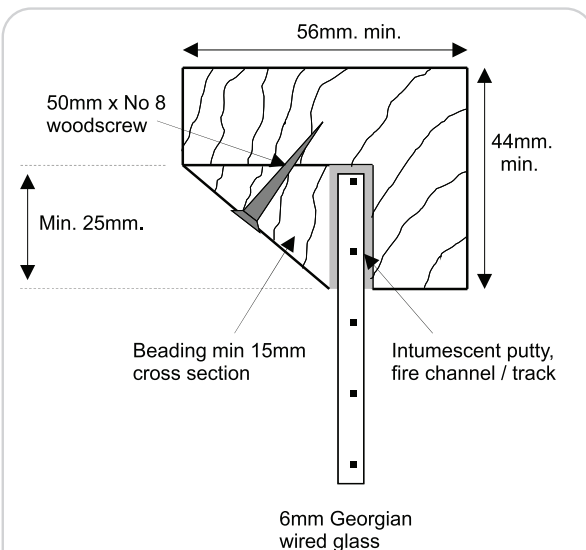

(iii) Cross section of glazed panel/window with glazing off-set to one side.

#### Note:

This guidance is for providing fire resisting glazing in partitions only. It does not relate to glazing in fire doors. A fire door has to be designed specifically to accommodate glazing. If glazing is required in a fire door then purpose made doors with glazing in situ should be obtained.

## Safety Glazing

Glazing in critical locations (i.e. where there is a danger of falling through or of lacerations) may need to meet both fire resistance and safety standards i.e the use of fire resisting safety glazing complying with current British Standard 6206: 1981 (or equivalent). See Diagram 3 for critical locations of safety glazing.

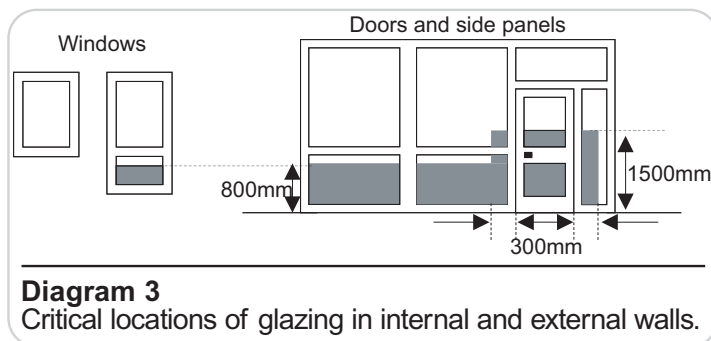

## 6F: Additional Escape Route Separation

### Electricity or Gas meter on escape route

Provide ½-hour fire resisting enclosure to the electric and gas meter. Enclosure to consist of 100mm x 50mm softwood framing faced with 12.5mm plasterboard both sides or alternatively 6mm fire protective board (e.g. Supalux) to the inner side of the framework, scrim joints and apply minimum 3mm plaster skim to outer surface. Provide ½-hour fire resisting door. Where a fire door is to be cut down to fit a smaller door opening, then solid core ½-hour fire resistant door blanks only are to be used. Hardwood lippings are to be glued and screwed to leaf edges once the door blank has been cut down to the required size. Ensure points where pipes or cables penetrate the cupboard are tightly sealed with a non-combustible compound capable of maintaining the ½-hour fire resistant integrity of the cupboard structure (e.g. intumescent foam etc).

Lead pipes are unsatisfactory and the gas supply pipes should be of high melting point metal. The cupboard to the gas meter should be provided with ventilation grills at high and low levels, these must provide ½ hour fire protection. The gas provider should be consulted to ensure they are satisfied with the arrangements, as they will require access to read meters.

### Loft Hatch

Loft hatches must provide the ½-hour fire resistance to the ceiling structure along the means of escape for the property.

Remove the existing loft hatch. Provide and fix suitable lining complete with minimum 25mm deep stops, both to be glued and screwed to loft hatch frame. Provide and fit ½-hour fire resistant loft hatch door to comprise solid core ½-hour fire door blank cut down to appropriate size, with hardwood lippings glued and screwed to each leaf edge. Provide and fit 10mm intumescent and smoke seals to be pinned into rebates on each leaf edge of the loft hatch door or alternatively into the loft hatch frame. The whole door to fit into the existing frame with no more than a 4mm gap at any point between the hatch door and the frame. 2-barrel bolts are to be provided and fitted on opposite sides of the exposed face to keep the hatch in a closed position under pressure when not in use.

### Under stairs cupboard

The soffit and spandrel partition to the staircase is to be made ½ hour fire resisting. Apply to the existing soffit and spandrel 12.5mm plasterboard with 3mm skim coat, or 6mm minimum fire protective board (e.g. SUPALUX) with all joints filled with fire resisting compound. The cupboard below the stairs at ground floor level, in addition to the above, is to have all combustible materials removed. Fit new ½-hour fire resisting door and frame. The door is to be kept locked shut. Apply notice to door reading "TO BE KEPT LOCKED SHUT", to comply with The Health and Safety (Safety Signs and Symbols) Regulations 1996.

## 6G: Guidance on the Fitting of Fire Doors and Frames

### ½ Hour fire Resistance

#### Frames

Where new frames are provided the gap between the frame and wall should be infilled with suitable material to achieve 30 minutes fire resistance. The provision of architrave to cover gaps in this location will not provide the necessary fire resistance.

#### Doors

Failure of fire resisting doors is very often due to burn through at the gap between door leaf and door frame. The fit of the door to frame is therefore extremely important and the gap should be as small as practical allowing the door to close freely. In the case of fire doors fitted with heat (intumescent) and cold smoke seals (FD 30S) the gap should not exceed that stated by the seal manufacturer usually 3 to 4 mm maximum. Both seals shall be fitted along both vertical and top edges of the door.

- Doors should be hung on 1½ pairs (i.e. 3) x 100mm steel butt hinges.
- The positions for fitting seals in door leafs are shown in the diagrams below.
- Seals can be fitted in the frame and if so they should align with the centre of the door leaf. Manufacturers' instructions should be adhered to when fitting seals.
- Smoke seals **MUST NOT** be painted over as this reduces their flexibility and effectiveness.
- Seals are not required to be fitted across the bottom of doors, but the threshold gap should not exceed 8mm.

#### Ironmongery

- Voids around the locking mechanism must be kept to a minimum and filled with intumescent paste or be encapsulated with a proprietary intumescent product.
- All doors required for means of escape must be capable of being opened from the inside without the use of a key. (i.e Yale type or thumb turn locks).
- The door stop of the frame should not be cut away to facilitate any lock or latch.
- The door must be fitted with a self-closing device capable of closing the door into the frame from any angle. Hydraulic overhead closers conforming to current British Standard 476 Part 22 (or equivalent), current British Standard 6459 (or equivalent) and current British Standard 8214 (or equivalent) are preferable as they are more efficient and reliable.

**Note:** Some overhead closers are not suitable for use on fire doors so it is always best to check with the supplier or manufacturer before purchasing. Automatic closing devices and electromagnetic hold open devices will be considered as an alternative to the overhead or perco type door closers where this is supported by a risk assessment.

Where concealed closers are allowed on fire doors it is recommended that these should be of the double chain hydraulically powered type.

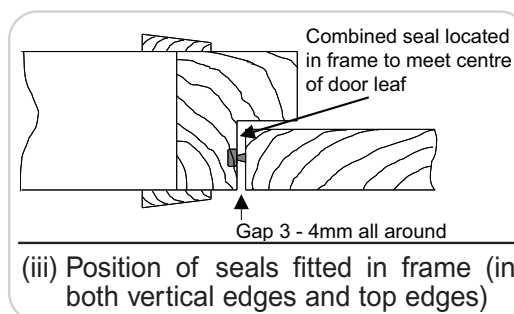
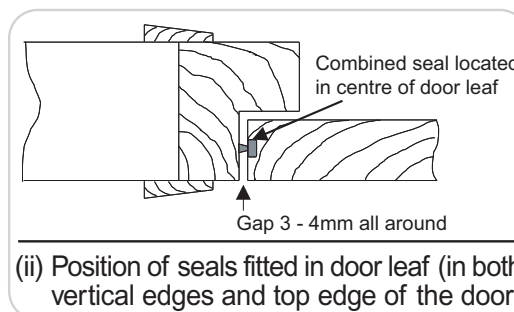
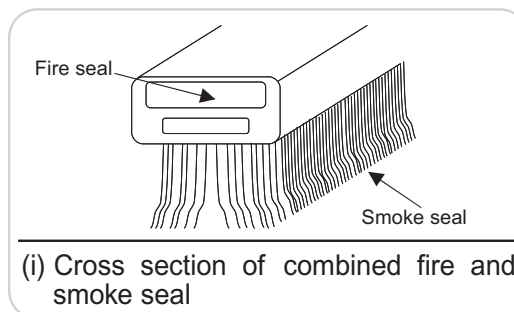

**Diagram 1** Guidance on the fitting of combined fire and smoke seals.

## **6H: The Design of Escape Windows**

Where window openings are likely to be used for means of escape purposes the following guidance must be referred to:

The window must have an unobstructed openable window area that is at least 0.33msq with at least the width or height dimension being a minimum of 450mm. Side hung opening lights are recommended. Care must be taken when considering the design (particularly with uPVC windows and their various hinge designs) to ensure the necessary openable area required is provided.

The bottom of the openable area (window cill level) must be not more than 1100mm, and not less than 800mm above floor level. Windows are suitable for means of escape where the drop from the window to ground level is one storey only (not exceeding 4.5m from first floor level to outside ground level).

**Note:** The ground below the windows must be flat and free from hazards (low walls, railings etc). Where security is provided on windows, means of opening must be readily available within the room. Where primary access to a sleeping room is through a high risk room (i.e. communal, kitchen or living room) an alternative suitable means of escape must be provided via a door or escape window directly to the outside.

**Part 7- SAMPLE FORM – Landlord fire safety checks**

See following two pages.

## **Landlord Fire Precaution Records**

This will help to provide evidence of your management and ongoing maintenance of the property.

**Fire Doors** - must close completely from a 45° angle, intumescent and smoke seals must be fitted correctly.  
**Common Parts** – must be kept clean, in good repair and free from obstructions. Any structural defects should also be noted and repaired – eg. Hole in wall.  
**Fire alarm** – routine testing of call points and detectors. An annual inspection by a competent electrician is required for BS 5839 Part 6 Grade A systems with a control panel. All false alarms shall also be recorded.  
**Emergency Lights** – a test key may be provided by the installer, alternatively you may turn the electricity off at the mains. Consult the system handbook.

<b>January</b>	Date Checked	Defects found	Actions Taken and date
Fire Doors			
Common Parts			
Fire Alarm			
Emergency Lights			
Signature of manager			
<b>February</b>	Date Checked	Defects found	Actions Taken and date
Fire Doors			
Common Parts			
Fire Alarm			
Emergency Lights			
Signature of manager			
<b>March</b>	Date Checked	Defects found	Actions Taken and date
Fire Doors			
Common Parts			
Fire Alarm			
Emergency Lights			
Signature of manager			
<b>April</b>	Date Checked	Defects found	Actions Taken and date
Fire Doors			
Common Parts			
Fire Alarm			
Emergency Lights			
Signature of manager			
<b>May</b>	Date Checked	Defects found	Actions Taken and date
Fire Doors			
Common Parts			
Fire Alarm			
Emergency Lights			
Signature of manager			
<b>June</b>	Date Checked	Defects found	Actions Taken and date
Fire Doors			
Common Parts			
Fire Alarm			
Emergency Lights			
Signature of manager			

<b>July</b>	Date Checked	Defects found	Actions Taken and date
Fire Doors			
Common Parts			
Fire Alarm			
Emergency Lights			
Signature of manager			
<b>August</b>	Date Checked	Defects found	Actions Taken and date
Fire Doors			
Common Parts			
Fire Alarm			
Emergency Lights			
Signature of manager			
<b>September</b>	Date Checked	Defects found	Actions Taken and date
Fire Doors			
Common Parts			
Fire Alarm			
Emergency Lights			
Signature of manager			
<b>October</b>	Date Checked	Defects found	Actions Taken and date
Fire Doors			
Common Parts			
Fire Alarm			
Emergency Lights			
Signature of manager			
<b>November</b>	Date Checked	Defects found	Actions Taken and date
Fire Doors			
Common Parts			
Fire Alarm			
Emergency Lights			
Signature of manager			
<b>December</b>	Date Checked	Defects found	Actions Taken and date
Fire Doors			
Common Parts			
Fire Alarm			
Emergency Lights			
Signature of manager			
<b>ANNUAL CHECKS</b> - Certificates must be kept detailing findings and contact details for the contractor			
	Date Checked & Company/Contractor details	Defects found	Actions Taken and date
Gas Safety			
Fire Alarm (Grade A system only)			
Electrical appliances			

## Part 8 – SPRINKLERS

Although fire sprinklers were invented in the UK in 1864 it was not until 1973 that their use for life safety was seriously investigated. Even since then the UK has not been proactive in extending and developing their use in residential premises despite many other countries passing local laws relating to them. Scottsdale in Arizona, introduced a requirement for sprinklers to be fitted to all new premises in 1985. The impact of this requirement was investigated after ten years and found that in properties with sprinklers there had been:

- No fire deaths
- 80% reduction in fire injuries
- 80% reduction in property damage
- 95% reduction for water usage for fire control

There is an extremely low risk of a false alarm with sprinklers and when one sprinkler is triggered it does not trigger any of the others. An auto dialler can be fitted to the system so that in the case of a sprinkler operating the call is transmitted to the fire brigade and the owner/manager automatically.

In short, should a fire occur the sprinkler suppresses the fire and douses it or contains it within that room. The damage that is caused by the water from the sprinkler is generally much less than the damage that would be caused by the fire, smoke and the water from the fire brigade in a property with traditional fire precautions. Sprinklers and associated pipe work can be fitted in the ceiling void and all that is visible is a small disc on the room ceiling.

**One of the main advantages to the landlord is design freedoms. These may include relaxation of the requirement for fire doors allowing properties to maintain traditional features, increased travel distances and a reduction in structural fire protection. A risk based assessment will be made as to the individual requirements for each property and detailed below is an example specification.**

### Sprinkler Specification

A residential sprinkler system designed, installed and maintained in accordance with B.S. 9251 2005 should be provided throughout the premises. The sprinkler system is to be installed by a contractor approved by The Fire Sprinkler Association – a list of approved contractors is available from them on request. Alternative qualifications may be acceptable; you should contact your Local Authority for approval of your contractor.

The sprinkler system is to be linked to an automatic fire detection system and where a sprinkler head is activated the fire alarm system shall also be activated. The type of fire detection system required will depend on the type and layout of the building. Again, guidance should be sought from your Local Authority. Generally, the requirements will match those required in the examples given in Part 4 of this document, with the exception that heat detectors are not required.

When the sprinkler system is activated audibility levels of 75db(A) are to be achieved at the bedhead in each room (with the bedsit doors closed). As a guide only - sounders positioned in the common areas producing approximately 100db(A) should be capable of producing this sound level at the bedhead. Where the sprinkler system is linked to the fire alarm system 'common' sounders for the 2 systems can be used, although the sprinkler system must still have its own external visual and audio alarm and a single internal audio alarm.

A monitored link/autodialler shall be installed so that when a sprinkler head is activated either the Fire Service or the landlord/responsible person for the property is contacted. The link is only to be activated when the sprinkler system is activated **not** when the fire alarm system is activated.

When installation is completed the approved sprinkler contractor is to provide the documentation detailed in section 6.3.2 of BS 9251. A copy of this is to be provided for the Local Authority.

The landlord or responsible person is to enter into a maintenance contract with a competent person or company to maintain the system in accordance with section 7 of BS 9251. Details of maintenance are to be available at reasonable request.

A system logbook to record every event involving the system is to be kept accessible and maintained.

